

PERIBEST F17 DATASHEET

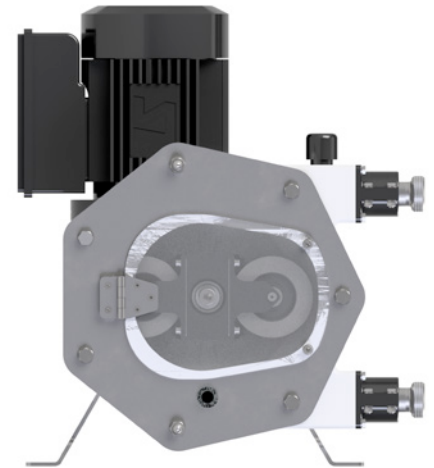

TECHNICAL SPECIFICATIONS	MODEL F17
Max. Flow (continuous)	500 l/h
Capacity	0,109 l/rev
Max. Discharge Pressure	10 bar
Max. Temperature	80 °C
Inner Diameter	16 mm.
Hose material	NBR Food grade (FDA)
Connections material	Stainless Steel AISI-316L
Connections type	DIN-11851, TRI-CLAMP
Pump casing material	Alluminium (powder coated)



MAIN FEATURES AND BENEFITS

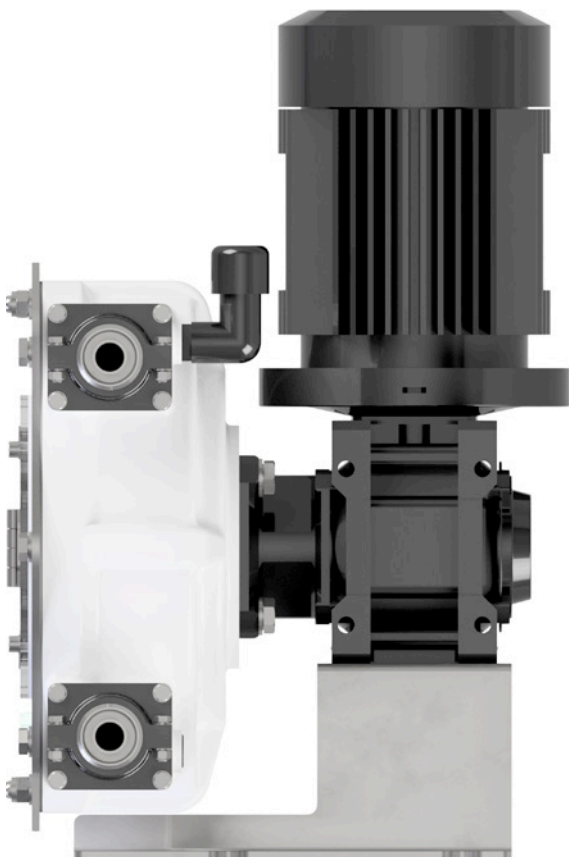

- 1 EASY AND QUICK TO REMOVE FRONT COVER AND ROLLER TO AID CIP CLEANING PROCESSES.**

OPTIMISES DOWNTIMES, FACILITATES CLEANING PROCESSES AND IMPROVES EFFICIENCY.

- 2 FOOD GRADE APPEARANCE WITH STAINLESS STEEL FRONT COVER, BASE PLATE, WHITE PAINTED PUMP BODY AND SANITARY FITTINGS.**

INCORPORATES THE NECESSARY MODIFICATIONS TO HAVE A COMPLETE SANITARY PUMP.

- 3 LATEST TECHNOLOGY PERISTALTIC HOSE.**

INNOVATE HOSE MANUFACTURING PROCESS PROVIDES EXTRA RESISTANCE AGAINST TEMPERATURE, LENGTHENS SERVICE LIFE AND REDUCES MAINTENANCE COSTS.

- 4 EXTREMELY HEAVY DUTY DESIGN FOR THE MOST DEMANDING APPLICATIONS UP TO 10 BAR.**

UNMATCHED PUMP LIFE AND EXCELLENT EQUIPMENT PERFORMANCE UNDER ANY OPERATING CONDITIONS HOWEVER DEMANDING.

**REQUIRED
MOTOR POWER (KW)**

**PRODUCT
TEMPERATURE (°C)**

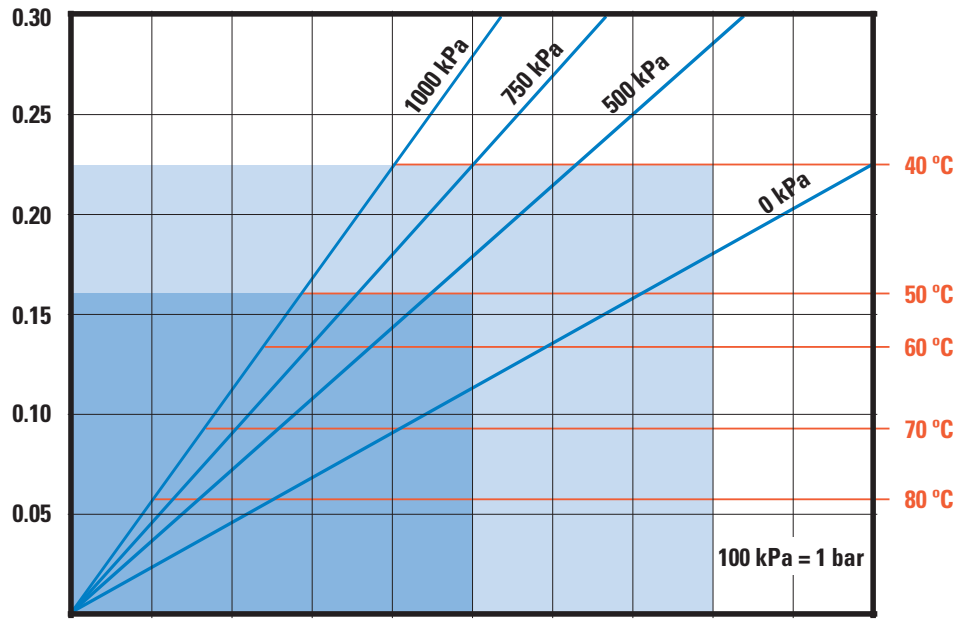

PUMP SPEED (RPM)	10	20	30	40	50	60	70	80	90	100
CAPACITY (L/H)	65	131	196	262	327	392	458	523	589	654

PRESSURE (kPa)	0 kPa	500 kPa	750 kPa	1000 kPa
TORQUE (Nm)	20	29	43	50

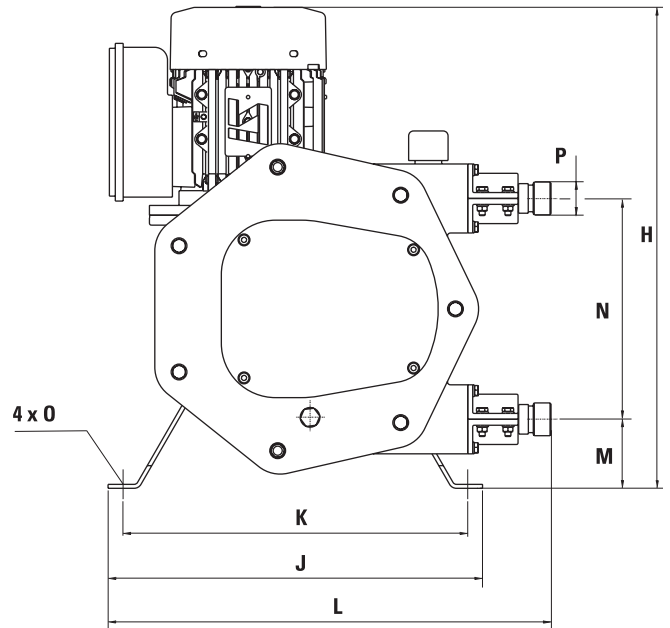
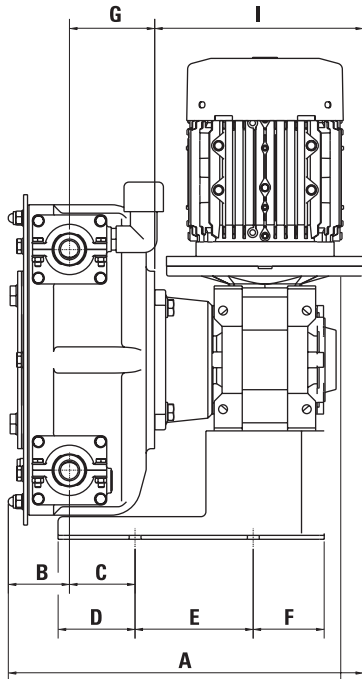

MODEL	A*	B	C	D	E	F	G	H	I*	J	K	L	M	N	O	P
F17	292,1	55,6	61	79,5	120	25,5	66,5	436,5	170	320	285	377,6	63	195	12	DIN-11851 DN20 • TRI-CLAMP ¼"

*Depending on the driver, dimensions could change.

www.peribest.com

Production Plant
PeriBest Pumps S.L.
 C/ Can Parellada, num. 26 Nave 10
 Pol. Ind. Sector H
 E-08170 Montornés del Vallés
Barcelona
 Tel. +34 935 992 214